













 **NEOTEK VISION**

Insertable a Pellets



Ref.2RA20PTGAKPCNL0002

DATOS TÉCNICOS

    9 KW	 0,99 - 1,98 Kg/h	 hasta 240 m <sup>3</sup>	
 7,9 KW	 80 M mm	 15 Kg	
 86%	 230 V	 92 Kg	 699 x 611 x 596 mm

CARACTERÍSTICAS

- Salida de humos: Superior;
- Estufa con dimensiones estándar para la mayoría de chimeneas construidas;
- Fácil de instalar, usar, encender y mantener;
- Laterales de vermiculita y sifón;
- Estructura en chapa de acero reforzada;
- Posibilidad de funcionamiento estanco conectando la toma de aire directamente desde el exterior;
- Sistema SMARTSTOVE incluido:

Termostato inalámbrico con conexión de hasta 10 metros.

Aplicación 4Heat para gestión remota

Receptor Pinkey

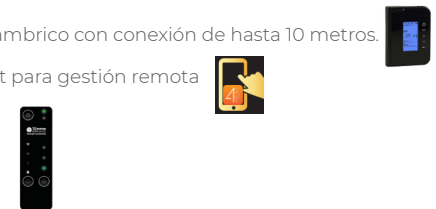

Controla tu **NEOTEK VISION** desde tu teléfono



Termostato  
2ways2+

App 4Heat

FUNCIONALIDADES



OPCIONAL

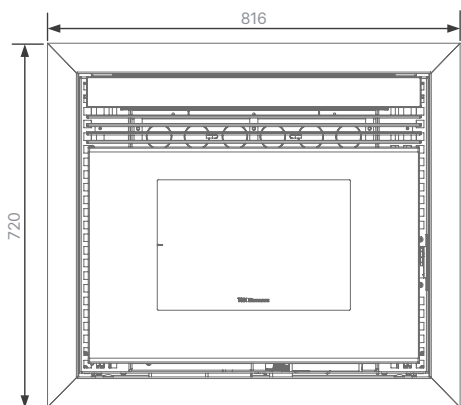

VISTA FRONTAL

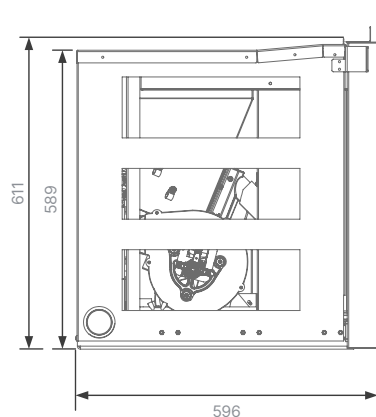

VISTA LATERAL

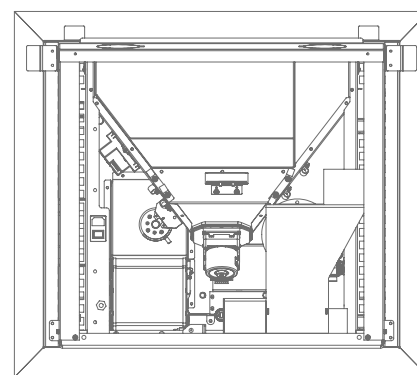



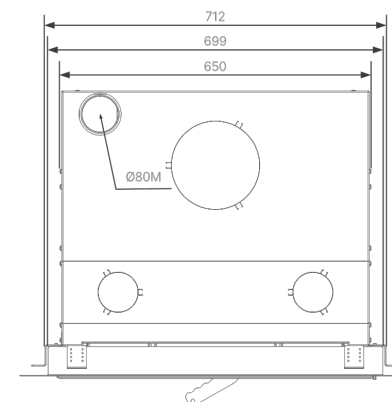









VISTA TRASERA



VISTA DE ARRIBA

DATOS TÉCNICOS

-  |  9 KW
-  0,99 - 1,98 Kg/h
-  hasta 240 m<sup>3</sup>
-  **A<sup>+</sup>** 
-  7,9 KW<sub>N</sub>
-  80 M mm
-  15 Kg
-  86%
-  230 V
-  92 Kg
-  699 x 611 x 596 mm

